

Wind Vane

Brass Housing, Rotor of Stainless Steel

Type VXV



- ✓ Patented.
- ✓ Special house.
- ✓ Special sand tightening.
- ✓ Contact less measuring.
- ✓ Absolute angle measurement up to 360°.
- ✓ No dead band
- ✓ High accuracy of measurement.
- ✓ Very long service lifetime.
- ✓ Output signals analogue or digital.
- ✓ High resolution.
- ✓ Heating units: 1 or 2 x 50 W, 24 VDC
- ✓ European patented no. 0813066

Product Description

The Wind Vane is made of brass, and is therefore very impervious to weather. It can be delivered with heating units, which ensure faultless function under extreme weather conditions. The Wind Vane can be configured to individual specifications.

The system is frictionless, which gives very high accuracy. It is possible to replace the heating units externally, without disassembling the Wind Vane.

Wind Vane
Brass Housing, Rotor of Stainless Steel
Type VXV



General Specifications	
Power supply voltage	24Vdc (16 ... 35Vdc)
Measuring range	360°.
Independent linearity	0,3%.
Max. repeatability	0,1°.
Resolution	(12 bit 360°)
Hysteresis	0,1°.
Min. Ohmic load at output	0.....500 Ohm
Min Lifetime (mechanical)	360 Mio.
Min Lifetime (electrical)	10 years.
Stock temperature range	-40. +85 °C.
Temperature range	-40. +85°C.
Storage temperature	Max 85°C.
Conform to	CE (89/336/CEE).
	EN 580081-1. EN 580081-1-2. EN 61000-6-2.

Output Specifications		Dimensions	
Analog system 0-360°	Output 4 -20mA.	Vane, length	237 mm
	Output 0-10V	Wind Vane	193 mm + 50 mm (Sensor included)
		Wind Vane	Ø60 (body)
		Packaging	28 x 28 x 22 cm

Materials	
Body	Brass (CuZn39Pb3-MS1658-04)
Rotor	Stainless steel (AISI 316)
Ball bearing	Stainless steel (INA 626.2 Z VA)
Rotor/housing tightening	Patented labyrinth
Environment	Operating temperature -25 to 70°C (-13 to 158°F) Storage temperature -25 to 120°C (-13 to 248°F) Heating system > -25°C (> -13°F) Climatic protection Against high humidity, salt and dust
Mounting	Mounting hole M12. Fasten 30Nm
Weight	(without sensors and heating) Approx. 1340 g

Wind Vane
 Brass Housing, Rotor of Stainless Steel
 Type VXV



Mode of Operation

The Wind Vane is usually placed approx. 10 m above ground level. It must be placed in a position where it is unimpeded by buildings and other wind-suppressing obstacles, so that turbulence at the instruments is reduced as much as possible. Wind Vane and adaptor must be mounted under observance of reliable craftsmanship and must be fastened in a way so that they present no danger to persons or goods, even at extreme blasts of wind. The pole and other devices forming part of the system must be effectively mutually connected to earthing systems for lightning protection and equipotential bonding.

Dimensions

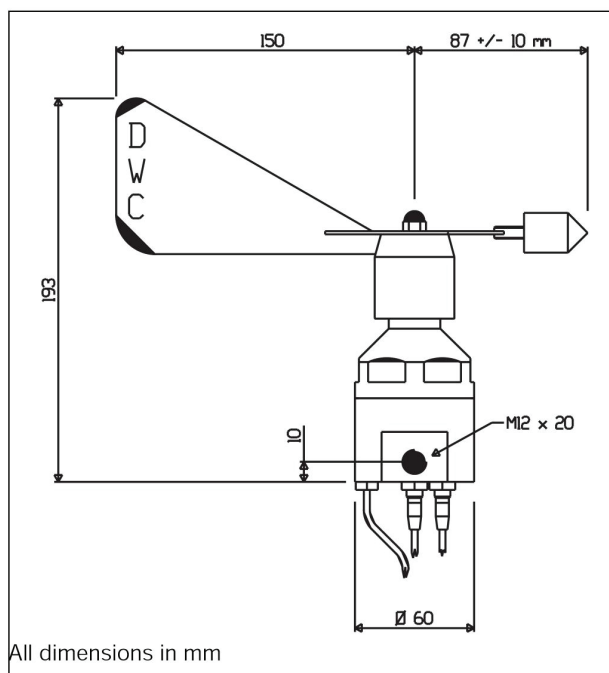

Colour Description

Black	- GND
Red Power supply	+ 16 – 35 Vdc
Brown Signal output	4 – 20 mA

Wrong connection may cause permanent damage to the wind vane

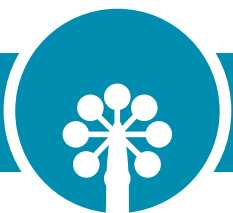

Wind Cluster®
 Creating Synergy